



---

# **UNIT 3**

# **PRECESSION**

---



## **COURSE OBJECTIVES**

To study about gyroscope and its effects during precession motion of moving vehicles.

## **COURSE OUTCOMES**

Knowledge acquired about Gyroscope and its precession motion.



## Introduction

When a body moves along a curved path with a uniform linear velocity, a force in the direction of centripetal acceleration (known as centripetal force) has to be applied externally over the body, so that it moves along the required curved path. This external force applied is known as **active force**.

When a body, itself, is moving with uniform linear velocity along a circular path, it is subjected to the centrifugal force\* radially outwards. This centrifugal force is called **reactive force**. The action of the reactive or centrifugal force is to tilt or move the body along radially outward direction.

## Precessional Angular Motion

We have already discussed that the angular acceleration is the rate of change of angular velocity with respect to time. It is a vector quantity and may be represented by drawing a vector diagram with the help

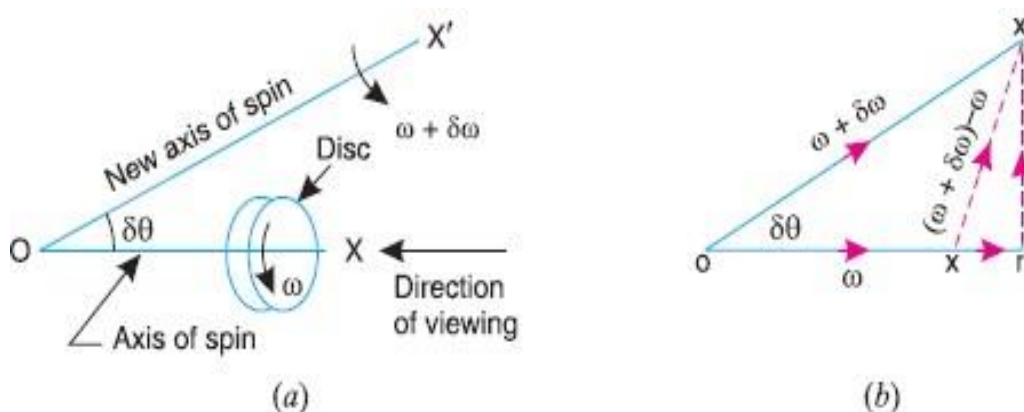

of right hand screw rule.

Consider a disc, as shown in Fig (a), revolving or spinning about the axis  $OX$  (known as **axis of spin**) in anticlockwise when seen from the front, with an angular velocity  $\omega$  in a plane at right angles to the paper.

After a short interval of time  $\delta t$ , let the disc be spinning about the new axis of spin  $OX'$  (at an angle  $\delta\theta$ ) with an angular velocity  $(\omega + \delta\omega)$ . Using the right hand screw rule, initial angular velocity of the disc ( $\omega$ ) is represented by vector  $ox$ ; and the final angular velocity of the disc  $(\omega + \delta\omega)$  is represented by vector  $ox'$  as shown in Fig. 14.1 (b). The vector  $xx'$  represents the change of angular velocity in time  $\delta t$  i.e. the angular

**Component of angular acceleration in the direction of  $ox$ ,**

$$\begin{aligned} \alpha_t &= \frac{xx'}{\delta t} = \frac{ox' - ox}{\delta t} = \frac{ox' \cos \delta\theta - ox}{\delta t} \\ &= \frac{(\omega + \delta\omega) \cos \delta\theta - \omega}{\delta t} = \frac{\omega \cos \delta\theta + \delta\omega \cos \delta\theta - \omega}{\delta t} \end{aligned}$$

Since  $\delta\theta$  is very small, therefore substituting  $\cos \delta\theta = 1$ , we have

$$\alpha_t = \frac{\omega + \delta\omega - \omega}{\delta t} = \frac{\delta\omega}{\delta t}$$

acceleration of the disc. This may be resolved into two components.

One parallel to  $ox$  and the other perpendicular to  $ox$ .



In the limit, when  $\delta t \rightarrow 0$ ,

$$\alpha_t = \lim_{\delta t \rightarrow 0} \left( \frac{\delta \omega}{\delta t} \right) = \frac{d\omega}{dt}$$

Component of angular acceleration in the direction perpendicular to  $ox$ ,

$$\alpha_c = \frac{rx'}{\delta t} = \frac{ox' \sin \delta \theta}{\delta t} = \frac{(\omega + \delta \omega) \sin \delta \theta}{\delta t} = \frac{\omega \sin \delta \theta + \delta \omega \cdot \sin \delta \theta}{\delta t}$$

Since  $\delta \theta$  is very small, therefore substituting  $\sin \delta \theta = \delta \theta$ , we have

$$\alpha_c = \frac{\omega \cdot \delta \theta + \delta \omega \cdot \delta \theta}{\delta t} = \frac{\omega \cdot \delta \theta}{\delta t}$$

...(Neglecting  $\delta \omega \cdot \delta \theta$ , being very small)

In the limit when  $\delta t \rightarrow 0$ ,

$$\alpha_c = \lim_{\delta t \rightarrow 0} \frac{\omega \cdot \delta \theta}{\delta t} = \omega \times \frac{d\theta}{dt} = \omega \cdot \omega_p \quad \dots \left( \text{Substituting } \frac{d\theta}{dt} = \omega_p \right)$$

$\therefore$  Total angular acceleration of the disc

= vector  $xx'$  = vector sum of  $\alpha_t$  and  $\alpha_c$

$$= \frac{d\omega}{dt} + \omega \times \frac{d\theta}{dt} = \frac{d\omega}{dt} + \omega \cdot \omega_p$$

Where  $d\theta/dt$  is the angular velocity of the axis of spin about a certain axis, which is perpendicular to the plane in which the axis of spin is going to rotate. This angular velocity of the axis of spin (i.e.  $d\theta/dt$ ) is known as angular velocity of precession and is denoted by  $\omega_p$ . The axis, about which the axis of spin is to turn, is known as axis of precession. The angular motion of the axis of spin about the axis of precession is known as precessional angular motion.

### Gyroscopic Couple

Consider a disc spinning with an angular velocity  $\omega$  rad/s about the axis of

spin  $OX$ , in anticlockwise direction when seen from the front, as shown in Fig. 14.2 (a). Since the plane in which the disc is rotating is parallel to the plane  $YOZ$ , therefore it is called plane of spinning. The plane  $XOZ$  is a horizontal plane and the axis of spin rotates in a plane parallel to the horizontal plane about an axis  $OY$ . In other words, the axis of spin is said to be rotating or processing about an axis  $OY$ . In other words, the axis of spin is said to be rotating or processing about an axis  $OY$  (which is perpendicular to both the axes  $OX$  and  $OZ$ ) at an angular velocity  $\omega_p$  rap/s. This horizontal plane  $XOZ$  is called plane of precession and  $OY$  is the axis of precession.

Let  $I$  = Mass moment of inertia of the disc about  $OX$ , and  $\omega$  = Angular velocity of the disc.

Angular momentum of the disc =  $I \cdot \omega$

Since the angular momentum is a vector quantity, therefore it may be represented by the vector  $ox'$ , as shown in Fig. 14.2 (b). The axis of spin  $OX$  is also rotating anticlockwise when seen from the top about the axis  $OY$ . Let the axis  $OX$  is turned in the plane  $XOZ$  through a small angle  $\delta \theta$  radians to the position  $OX'$ , in



time  $\delta t$  seconds. Assuming the angular velocity  $\omega$  to be constant, the angular momentum will now be represented by vector  $ox'$ .

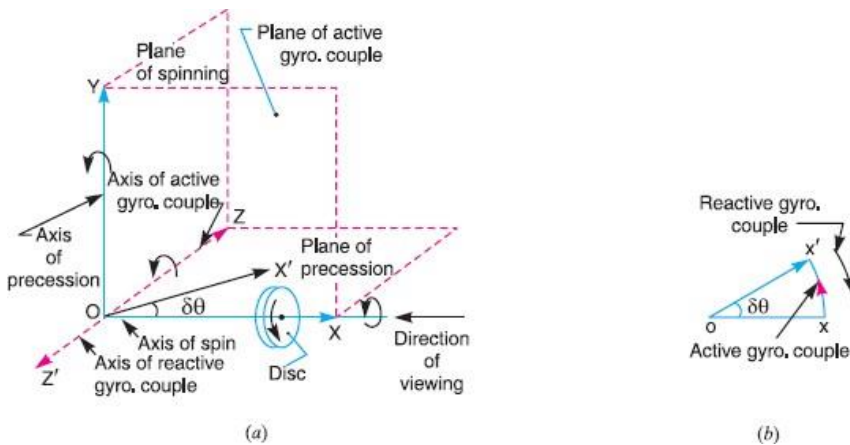

$$= ox' - ox = xx' = ox \cdot \delta\theta \quad \dots(\text{in the direction of } xx')$$

$$= I \cdot \omega \cdot \delta\theta$$

Change in angular momentum and rate of change of angular momentum

$$= I \cdot \omega \times \frac{\delta\theta}{dt}$$

$$C = \lim_{\delta t \rightarrow 0} I \cdot \omega \times \frac{\delta\theta}{\delta t} = I \cdot \omega \times \frac{d\theta}{dt} = I \cdot \omega \cdot \omega_p \quad \dots \left( \because \frac{d\theta}{dt} = \omega_p \right)$$

Since the rate of change of angular momentum will result by the application of a couple to the disc,

Therefore the couple applied to the disc causing precession,

Where  $\omega_p$  = Angular velocity of precession of the axis of spin or the speed of rotation of the axis of spin about the axis of precession OY.

The couple  $I \cdot \omega \cdot \omega_p$ , in the direction of the vector  $xx'$  (representing the change in angular momentum) is the *active gyroscopic couple*, which has to be applied over the disc when the axis of spin is made to rotate with angular velocity  $\omega_p$  about the axis of precession. The vector  $xx'$  lies in the plane XOZ or the horizontal plane. In case of a very small displacement  $\delta\theta$ , the vector  $xx'$  will be perpendicular to the vertical plane XOY. Therefore the couple causing this change in the angular momentum will lie in the plane XOY. The vector  $xx'$ , as shown in Fig(b), represents an anticlockwise couple in the plane XOY. Therefore, the plane XOY is called the *plane of active gyroscopic couple* and the axis OZ perpendicular to the plane XOY, about which the couple acts, is called the axis of active gyroscopic couple.

When the axis of spin itself moves with angular velocity  $\omega_p$ , the disc is subjected to *reactive couple* whose magnitude is same (i.e.  $I \cdot \omega \cdot \omega_p$ ) but opposite in direction to that of active couple. This reactive couple to which the disc is subjected when the axis of spin



rotates about the axis of precession is known as *reactive gyroscopic couple*. The axis of the reactive gyroscopic couple is represented by  $OZ'$  in Fig(a).

The gyroscopic couple is usually applied through the bearings which support the shaft. The bearings will resist equal and opposite couple.

The gyroscopic principle is used in an instrument or toy known as gyroscope. The gyroscopes are installed in ships in order to minimize the rolling and pitching effects of waves. They are also used in aero planes, monorail cars, gyrocompasses etc.

**Effect of the Gyroscopic Couple on an aero plane:**

The top and front view of an aero plane is shown in Fig (a). Let engine or propeller rotates in the clockwise direction when seen from the rear or tail end and the aero plane takes a turn to the left.

Let  $\omega$  = Angular velocity of the engine in rad/sec,

$m$  = Mass of the engine and the propeller in kg,

$k$  = Its radius of gyration in metre

$I$  = Mass moment of inertia of the engine and the propeller in  $kg\cdot m^2$

$$= mk^2$$

$v$  = Linear velocity of the aero plane in m/s,

$R$  = Radius of curvature in metres, and

$\omega_p$  = Angular velocity of precession= $V/R$

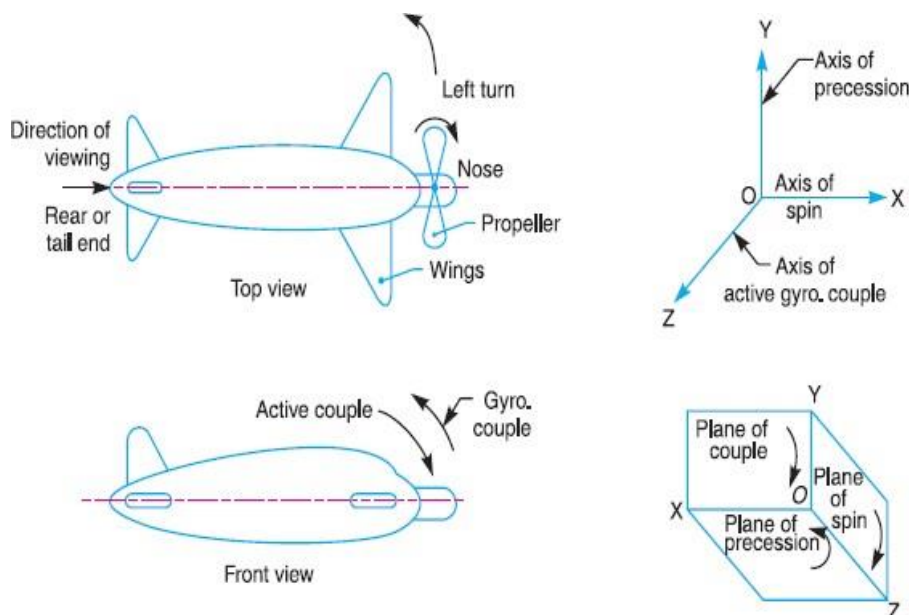

Before taking the left turn, the angular momentum vector is represented by  $ox$ . When it takes left turn, the active gyroscopic couple will change the direction of the angular momentum vector from  $ox$  to  $ox'$  as shown in Fig(a). The vector  $xx'$ , in the limit, represents the change of angular momentum or the active gyroscopic couple and is perpendicular to  $ox$ . Thus the plane of active gyroscopic couple  $XOY$  will be perpendicular to  $xx'$ , i.e. vertical in this case, as shown in Fig (b). By applying right hand screw rule to vector  $xx'$ , we find that the direction of active gyroscopic couple is clockwise as shown in the front view of Fig (a).

In other words, for left hand turning, the active gyroscopic couple on the aero plane in the axis  $OZ$  will be clockwise as shown in Fig (b). The reactive gyroscopic couple (equal in magnitude of active gyroscopic

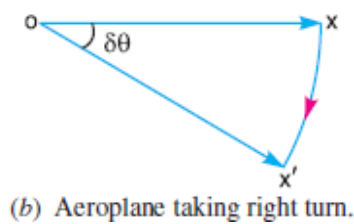
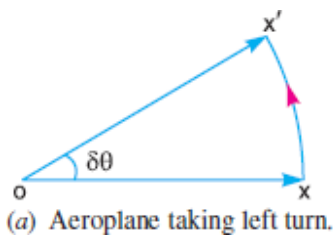

couple) will act in the opposite direction (i.e. in the anticlockwise direction) and the effect of this couple is, therefore, to raise the nose and dip the tail of the aero plane.

Terms Used in a Naval Ship.

The top and front views of a naval ship are shown in Fig 14.7. The fore end of the ship is called **bow** and the rear end is known as **stern** or **aft**. The left hand and right hand sides of the ship, when viewed from the stern are called **port** and **star-board** respectively. We shall now discuss the effect of gyroscopic couple on the naval ship in the following three cases:

Steering,

Pitching,

Rolling.

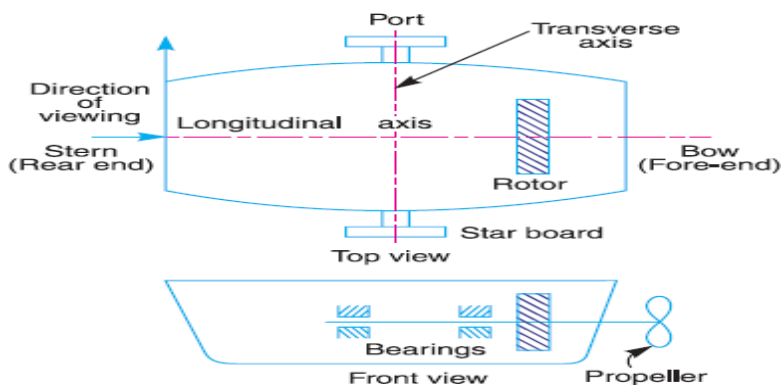

## Effect of Gyroscopic Couple on a Naval Ship during Steering

Steering is the turning of a complete ship in a curve towards left or right, while it moves forward. Consider the ship taking a left turn, and rotor rotates in the clockwise direction when viewed from the stern, as shown in Fig. The effect of gyroscopic couple on a naval ship during steering taking left or right turn may be obtained in the similar way as for an aeroplane.

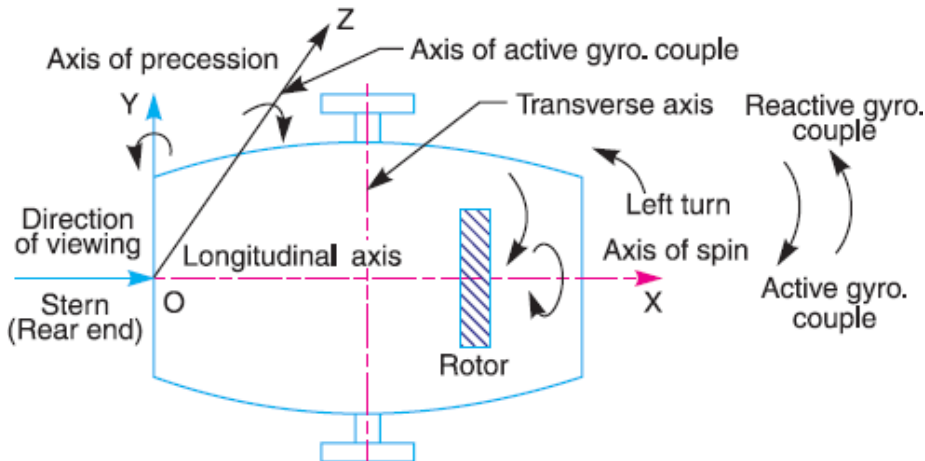

When the rotor of the ship rotates in the clockwise direction when viewed from the stern, it will have its angular momentum vector in the direction  $ox$  as shown in Fig(a). As the ship steers to the left, the active gyroscopic couple will change the angular momentum vector from  $ox$  to  $ox'$ . The vector  $xx'$  now represents the active gyroscopic couple and is perpendicular to  $ox$ . Thus the plane of active gyroscopic couple is perpendicular to  $xx'$  and its direction in the axis  $OZ$  for left hand turn is clockwise as shown in Fig. The reactive gyroscopic couple of the same magnitude will act in the opposite direction (i.e. in anticlockwise direction). The effect of this reactive gyroscopic couple is to raise the bow and lower the stern.

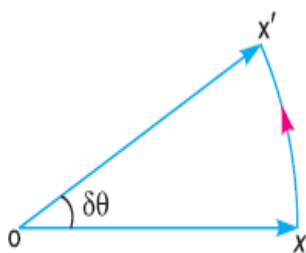

(a) Steering to the left

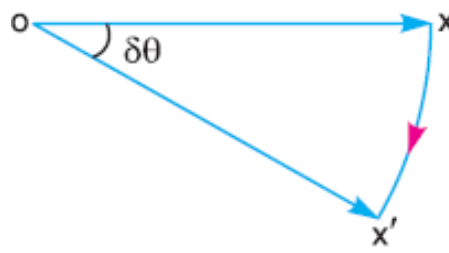

(b) Steering to the right





## Effect of Gyroscopic Couple on a Naval Ship during Pitching

Pitching is the movement of a complete ship up and down in a vertical plane about transverse axis, as shown in Fig(a). In this case, the transverse axis is the axis of precession. The pitching of the ship is assumed to take place with simple harmonic motion i.e. the motion of the axis of spin about transverse

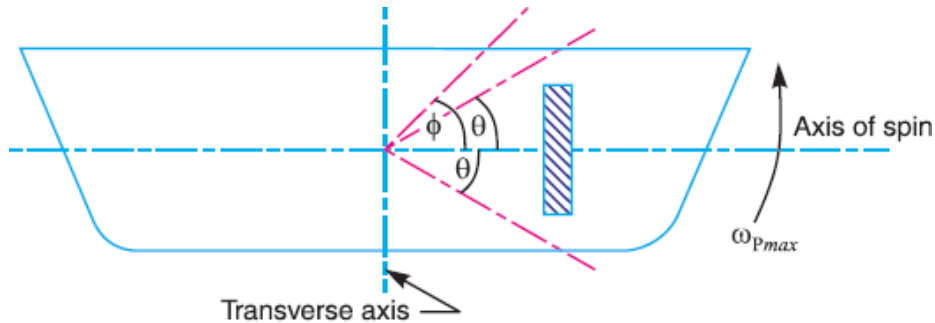

(a) Pitching of a naval ship

axis is simple harmonic.

Let  $I$  = Moment of inertia of the rotor in  $\text{kg-m}^2$ , and  $\omega$  = Angular velocity of the rotor in  $\text{rad/s}$ .

Minimum gyroscopic couple,

$$C_{max} = I. \omega. \omega_{Pmax}$$

When the pitching is upward, the effect of the reactive gyroscopic couple, as shown in Fig.(b), will try to move the ship toward star-board. On the other hand, if the pitching is downward, the effect of the reactive gyroscopic couple, as shown in Fig(c), is to turn the ship towards port side.

## Effect of Gyroscopic Couple on a Naval Ship during Rolling

We know that, for the effect of gyroscopic couple to occur, the axis of precession should always be perpendicular to the axis of spin. If, however, the axis of precession becomes parallel to the axis of spin, there will be no effect of the gyroscopic couple acting on the body of the ship.

In case of rolling of a ship, the axis of precession (*i.e.* longitudinal axis) is always parallel to the axis of spin for all positions. Hence, there is no effect of the gyroscopic couple acting on the body of a ship.

## Stability of a Four Wheel Drive Moving in a Curved Path



Consider the four wheels  $A$ ,  $B$ ,  $C$  and  $D$  of an automobile locomotive taking a turn towards left as shown in Fig. The wheels  $A$  and  $C$  are inner wheels, whereas  $B$  and  $D$  are outer wheels. The centre of gravity (C.G.) of the vehicle lies vertically above the road surface.

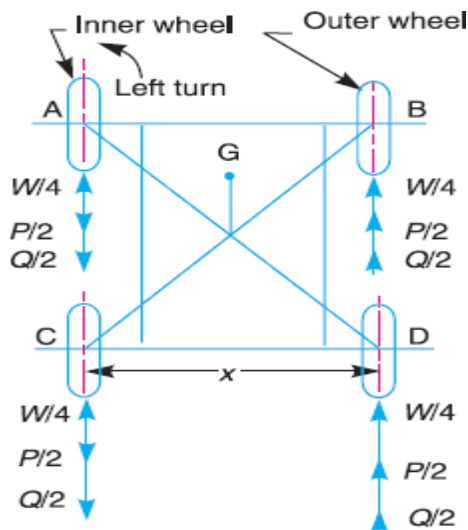

Let  $m$  = Mass of the vehicle in kg,

$W$  = Weight of the vehicle in newtons =  $m.g$ ,  $r_w$  = Radius of the wheels in metres,

$R$  = Radius of curvature in metres ( $R > r_w$ ),

$h$  = Distance of centre of gravity, vertically above the road surface in metres,

$x$  = Width of track in metres,

$I_w$  = Mass moment of inertia of one of the wheels in  $\text{kg}\cdot\text{m}^2$ ,

$\omega_w$  = Angular velocity of the wheels or velocity of spin in rad/s,

$I_E$  = Mass moment of inertia of the rotating parts of the engine in  $\text{kg}\cdot\text{m}^2$

$\omega_E$  = Angular velocity of the rotating parts of the engine in rad/s,

$G$  = Gear ratio =  $\omega_E/\omega_w$

$v$  = Linear velocity of the vehicle in m/s =  $\omega_w \cdot r_w$

A little consideration will show that the weight of the vehicle ( $W$ ) will be equally distributed over the four wheels which will act downwards. The reaction between each wheel and the road surface of the same magnitude will act upwards.



**Therefore Road reaction over each wheel =  $W/4 = m.g/4$  newtons**

Let us now consider the effect of the gyroscopic couple and centrifugal couple on the vehicle.

∴ Angular displacement of the axis of spin from mean position after time  $t$  seconds,

$$\theta = \phi \sin \omega_1 \cdot t$$

$\phi$  = Amplitude of swing *i.e.* maximum angle turned from the mean position in radians, and

$\omega_1$  = Angular velocity of S.H.M.

$$= \frac{2\pi}{\text{Time period of S.H.M. in seconds}} = \frac{2\pi}{t_p} \text{ rad/s}$$

Angular velocity of precession,

$$\omega_p = \frac{d\theta}{dt} = \frac{d}{dt}(\phi \sin \omega_1 \cdot t) = \phi \omega_1 \cos \omega_1 t$$

The angular velocity of precession will be maximum, if  $\cos \omega_1 t = 1$ .

∴ Maximum angular velocity of precession,

$$\omega_{pmax} = \phi \cdot \omega_1 = \phi \times 2\pi / t_p$$

...(Substituting  $\cos \omega_1 t = 1$ )

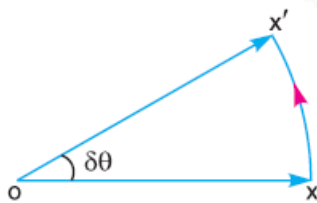

(b) Pitching upward

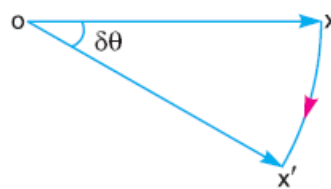

(c) Pitching downward

Effect of the gyroscopic couple

Since the vehicle takes a turn towards left due to the precession and other rotating parts, therefore a gyroscopic couple will act.

We know that velocity of precession,  $\omega_p = v/R$

Gyroscopic couple due to 4 wheels,

$$C_W = 4 I_W \cdot \omega_W \cdot \omega_p$$

and gyroscopic couple due to the rotating parts of the engine,

$$C_E = I_E \cdot \omega_E \cdot \omega_p = I_E \cdot G \cdot \omega_W \cdot \omega_p$$

Net gyroscopic couple,

$$C = C_W \pm C_E = 4 I_W \cdot \omega_W \cdot \omega_p \pm I_E \cdot G \cdot \omega_W \cdot \omega_p$$



$$= \omega_W \cdot \omega_P (4 I_W \pm G \cdot I_E)$$

The **positive** sign is used when the wheels and rotating parts of the engine rotate in the same direction. If the rotating parts of the engine revolve in opposite direction, then **negative** sign is used.

Due to the gyroscopic couple, vertical reaction on the road surface will be produced. The reaction will be vertically upwards on the outer wheels and vertically downwards on the inner wheels.

Let the magnitude of this reaction at the two outer or inner wheels be  $P$  new tons. Then

$$P \times x = C \text{ or } P = C/x$$

Vertical reaction at each of the outer or inner wheels,

$$P / 2 = C/2x$$

Effect of the centrifugal couple

Since the vehicle moves along a curved path, therefore centrifugal force will act outwardly at the centre of gravity of the vehicle. The effect of this centrifugal force is also to overturn the vehicle.

$$F_C = \frac{m \times v^2}{R}$$

We know that centrifugal force,

The couple tending to overturn the vehicle or overturning couple,

$$C_O = F_C \times h = \frac{m \cdot v^2}{R} \times h$$

This overturning couple is balanced by vertical reactions, which are vertically up wards on the outer wheels and vertically downwards on the inner wheels. Let the magnitude of this reaction at the two outer

$$Q \times x = C_O \text{ or } Q = \frac{C_O}{x} = \frac{m \cdot v^2 \cdot h}{R \cdot x}$$

or inner wheels be  $Q$ . Then

Vertical reaction at each of the outer or inner wheels,

Total vertical reaction at each of the outer wheel,

$$\frac{Q}{2} = \frac{m \cdot v^2 \cdot h}{2R \cdot x}$$



$$P_0 = \frac{W}{4} + \frac{P}{2} + \frac{Q}{2}$$

Total vertical reaction at each of the inner wheel

$$P_1 = \frac{W}{4} - \frac{P}{2} - \frac{Q}{2}$$

A little consideration will show that when the vehicle is running at high speeds,  $P_1$  may be zero or even negative. This will cause the inner wheels to leave the ground thus tending to overturn the automobile. In order to have the contact between the inner wheels and the ground, the sum of  $P/2$  and  $Q/2$  must be less than  $W/4$ .

### Stability of a Two Wheel Vehicle Taking a Turn

Consider a two wheel vehicle (say a scooter or motor cycle) taking a right turn as shown in fig.

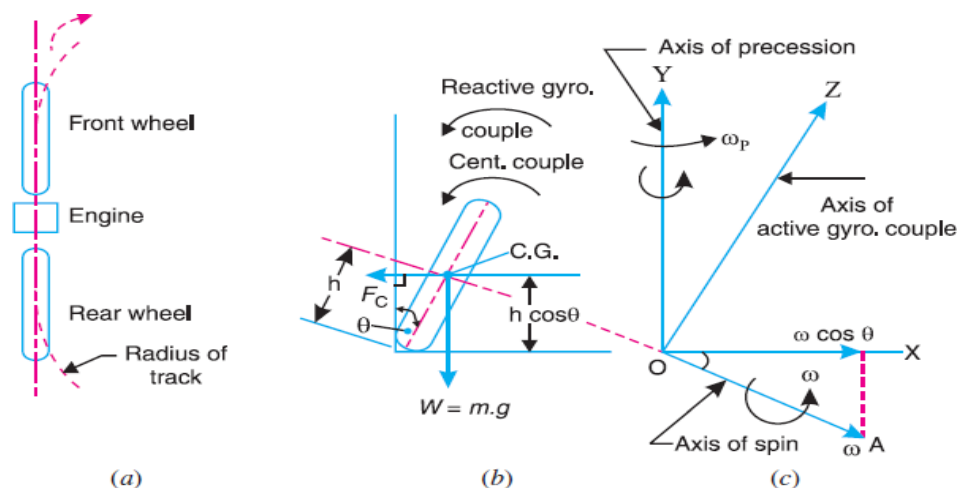

Let

$m$  = Mass of the vehicle and its rider in kg,

$W$  = Weight of the vehicle and its rider in Newton's =  $m.g$ ,  $h$  = Height of the centre of gravity of the vehicle and rider,  $r_w$  = Radius of the wheels,

$R$  = Radius of track or curvature,

$I_w$  = Mass moment of inertia of each wheel,

$I_E$  = Mass moment of inertia of the rotating parts of the engine,  $\omega_w$  = Angular velocity of the wheels,

$\omega_E$  = Angular velocity of the engine,

$$G = \text{Gear ratio} = \omega_E / \omega_w,$$



$v =$  Linear velocity of the vehicle  $= \omega_W \times r_W$ ,

$\theta =$  Angle of wheel. It is inclination of the vehicle to the vertical for equilibrium.

Let us now consider the effect of the gyroscopic couple and centrifugal couple on the vehicle,

Effect of gyroscopic couple

$$\omega_E = G \cdot \omega_W = G \times \frac{v}{r_W}$$

$$\begin{aligned} \therefore \text{Total } (I \times \omega) &= 2 I_W \times \omega_W \pm I_E \times \omega_E \\ &= 2 I_W \times \frac{v}{r_W} \pm I_E \times G \times \frac{v}{r_W} = \frac{v}{r_W} (2 I_W \pm G I_E) \end{aligned}$$

We know that  $v = \omega_W \times r_W$  or  $\omega_W = v / r_W$

Velocity of precession,  $\omega_P = v / R$

A little consideration will show that when the wheels move over the curved path, the vehicle is always inclined at an angle  $\theta$  with the vertical plane as shown in Fig (b). This angle is known as **angle of heel**. In other words, the axis of spin is inclined to the horizontal at an angle  $\theta$ , as shown in Fig (c). Thus the angular

Momentum vector  $I\omega$  due to spin is represented by  $OA$  inclined to  $OX$  at an angle  $\theta$ . But the precession

Gyroscopic couple,

$$\begin{aligned} C_1 &= I \cdot \omega \cos \theta \times \omega_P = \frac{v}{r_W} (2 I_W \pm G I_E) \cos \theta \times \frac{v}{R} \\ &= \frac{v^2}{R \cdot r_W} (2 I_W \pm G I_E) \cos \theta \end{aligned}$$

axis is vertical. Therefore the spin vector is resolved along  $OX$ .

Effect of centrifugal couple

We know that centrifugal force,

$$F_C = \frac{m \cdot v^2}{R}$$

This force acts horizontally through the centre of gravity (C.G.) along the outward direction.

$$C_2 = F_C \times h \cos \theta = \left( \frac{m \cdot v^2}{R} \right) h \cos \theta$$



Centrifugal couple,

Since the centrifugal couple has a tendency to overturn the vehicle, therefore Total overturning couple,

$C_O = \text{Gyroscopic couple} + \text{Centrifugal couple}$

$$\begin{aligned} &= \frac{v^2}{R.r_W} (2 I_W + G.I_E) \cos \theta + \frac{m.v^2}{R} \times h \cos \theta \\ &= \frac{v^2}{R} \left[ \frac{2 I_W + G.I_E}{r_W} + m.h \right] \cos \theta \end{aligned}$$

We know that balancing couple =  $m.g.h \sin \theta$

The balancing couple acts in clockwise direction when seen from the front of the vehicle. Therefore for stability, the overturning couple must be equal to the balancing couple, *i.e.*

$$\frac{v^2}{R} \left( \frac{2 I_W + G.I_E}{r_W} + m.h \right) \cos \theta = m.g.h \sin \theta$$

From this expression, the value of the angle of heel ( $\theta$ ) may be determined, so that the vehicle does not skid.

## PROBLEMS

### Example 1.

A uniform disc of diameter 300 mm and of mass 5 kg is mounted on one end of an arm of length 600 mm. The other end of the arm is free to rotate in a universal bearing. If the disc rotates about the arm with a speed of 300 r.p.m. clockwise, looking from the front, with what speed will it precess about the vertical axis?

**Solution.** Given:  $d = 300 \text{ mm}$  or  $r = 150 \text{ mm} = 0.15 \text{ m}$ ;  $m = 5 \text{ kg}$ ;  $l = 600 \text{ mm} = 0.6 \text{ m}$   
 $N = 300 \text{ r.p.m.}$  or  $\omega = 2\pi \times 300/60 = 31.42 \text{ rad/s}$

We know that the mass moment of inertia of the disc, about an axis through its centre of gravity and perpendicular to the plane of disc,

$$I = m.r^2/2 = 5(0.15)^2/2 = 0.056 \text{ kg-m}^2$$

couple due to mass of disc,

$$C = m.g.l = 5 \times 9.81 \times 0.6 = 29.43 \text{ N-m}$$

Let  $\omega_P = \text{Speed of precession.}$

We know that couple (C),



$$29.43 = I \cdot \omega \cdot \omega_p = 0.056 \times 31.42 \times \omega_p = 1.76 \omega_p$$

$$\omega_p = 29.43/1.76 = 16.7 \text{ rad/s}$$

### Example 2.

An aeroplane makes a complete half circle of 50 metres radius, towards left, when flying at 200 km per hr. The rotary engine and the propeller of the plane has a mass of 400 kg and a radius of gyration of 0.3 m. The engine rotates at 2400 r.p.m. clockwise when viewed from the rear. Find the gyroscopic couple on the aircraft and state its effect on it.

**Solution:** Given :  $R = 50 \text{ m}$  ;  $v = 200 \text{ km/hr} = 55.6 \text{ m/s}$  ;  $m = 400 \text{ kg}$  ;  $k = 0.3 \text{ m}$  ;  $N =$

**2400 r.p.m. or  $\omega = 2\pi \times 2400/60 = 251 \text{ rad/s}$**

We know that mass moment of inertia of the engine and the propeller,

$$I = m \cdot k^2 = 400(0.3)^2 = 36 \text{ kg-m}^2$$

Angular velocity of precession,  $\omega_p = v/R = 55.6/50 = 1.11 \text{ rad/s}$

We know that gyroscopic couple acting on the aircraft,

$$C = I \cdot \omega \cdot \omega_p = 36 \times 251.4 \times 1.11 = 10046 \text{ N-m} = 10.046 \text{ kN-m}$$

When the aeroplane turns towards left, the effect of the gyroscopic couple is to lift the nose upwards and tail downwards.

**Example 3 :** The turbine rotor of a ship has a mass of 8 tonnes and a radius of gyration 0.6 m. It rotates at 1800 r.p.m. clockwise, when looking from the stern. Determine the gyroscopic couple, if the ship travels at 100 km/hr and steer to the left in a curve of 75 m radius.

**Solution.** Given:  $m = 8 \text{ t} = 8000 \text{ kg}$  ;  $k = 0.6 \text{ m}$  ;  $N = 1800 \text{ r.p.m. or } \omega = 2\pi \times 1800/60 = 188.5 \text{ rad/s}$  ;  
 $v = 100 \text{ km/h} = 27.8 \text{ m/s}$  ;  $R = 75 \text{ m}$

We know that mass moment of inertia of the rotor,

$$I = m \cdot k^2 = 8000 (0.6)^2 = 2880 \text{ kg-m}^2$$

Angular velocity of precession,

$$\omega_p = v / R = 27.8 / 75 = 0.37 \text{ rad/s}$$

We know that gyroscopic

$$C = I \cdot \omega \cdot \omega_p = 2880 \times 188.5 \times 0.37 = 200866 \text{ N-m}$$

$$= 200.866 \text{ kN-m}$$





When the rotor rotates in clockwise direction when looking from the stern and the ship steers to the left, the effect of the reactive gyroscopic couple is to raise the bow and lower the stern.



## INDUSTRIAL APPLICATIONS OF GYROSCOPIC

1. Motor car
2. Motor cycle
3. Aero planes
4. Ships

5. Applications of gyroscopes include inertial navigation systems, such as in the Hubble Telescope, or inside the steel hull of a submerged submarine. Due to their precision, gyroscopes are also used in gyrotheodolites to maintain direction in tunnel mining.

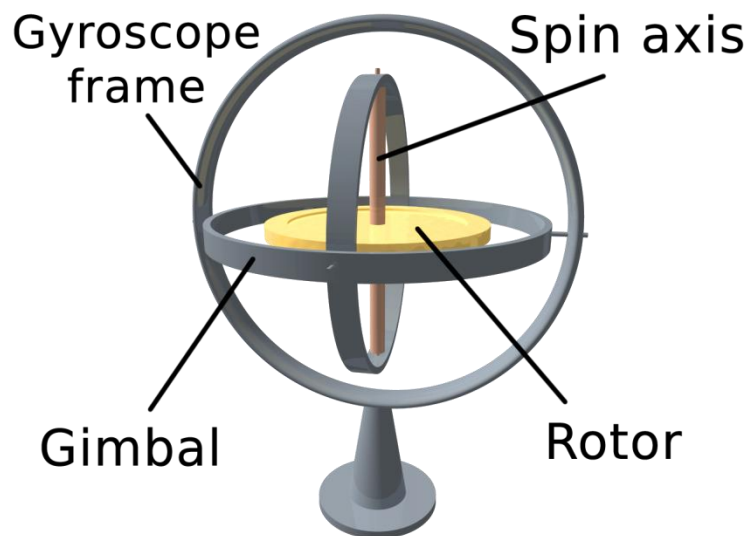

## Gyroscopic Effect ( Simple Trick )

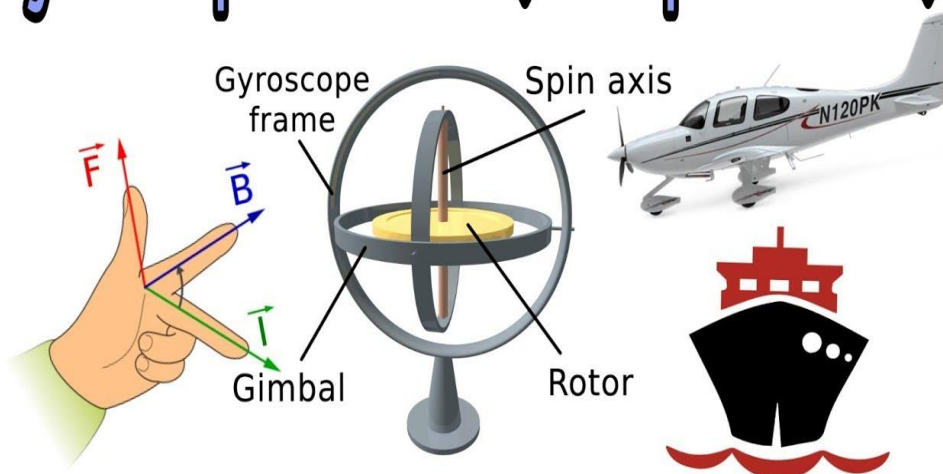

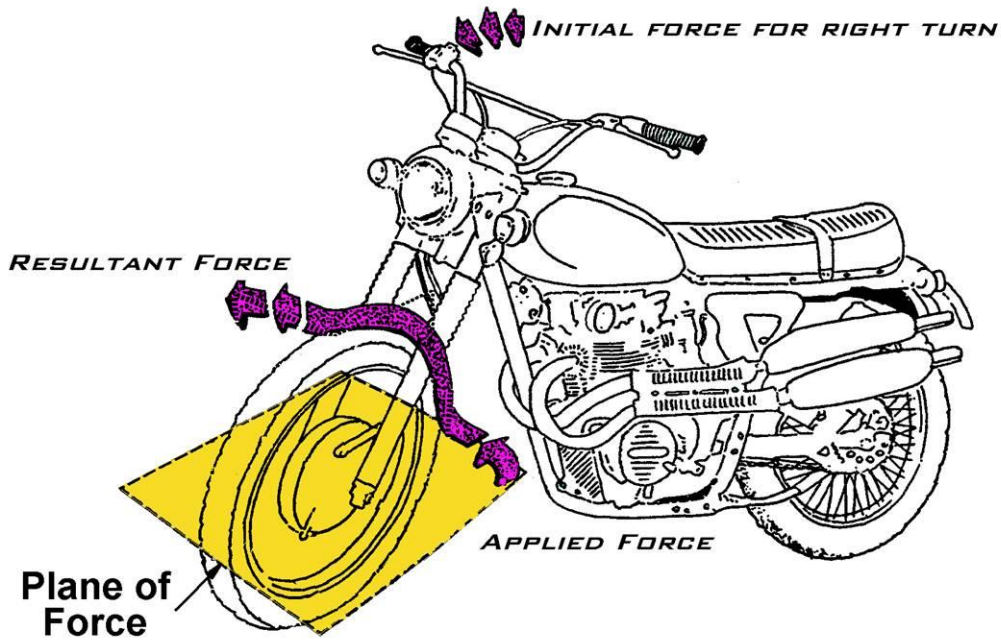

## TUTORIAL QUESTIONS

1. What do you understand by gyroscopic couple? Derive a formula for its magnitude.
2. Explain the effect of the gyroscopic couple on the reaction of the four wheels of a vehicle negotiating a curve.
3. Discuss the effect of the gyroscopic couple on a two wheeled vehicle when taking a turn.
4. What will be the effect of the gyroscopic couple on a disc fixed at a certain angle to a rotating shaft?
5. A flywheel of mass 10 kg and radius of gyration 200 mm is spinning about its axis, which is horizontal and is suspended at a point distant 150 mm from the plane of rotation of the flywheel. Determine the angular velocity of precession of the flywheel. The spin speed of flywheel is 900 r.p.m.
6. Find the angle of inclination with respect to the vertical of a two wheeler negotiating a turn. Given : combined mass of the vehicle with its rider 250 kg ; moment of inertia of the engine flywheel 0.3 kg-m<sup>2</sup> ; moment of inertia of each road wheel 1 kg-m<sup>2</sup> ; speed of engine flywheel 5 times that of road wheels and in the same direction ; height of centre of gravity of rider with vehicle 0.6 m ; two wheeler speed 90 km/h ; wheel radius 300 mm ; radius of turn 50 m.
7. A pair of locomotive driving wheels with the axle, have a moment of inertia of 180 kg-m<sup>2</sup>. The diameter of the wheel treads is 1.8 m and the distance between wheel centres is 1.5 m. When the locomotive is travelling on a level track at 95 km/h, defective ballasting causes one wheel to fall 6 mm and to rise again in a total time of 0.1 s. If the displacement of the wheel takes place with simple harmonic motion, find: 1. The gyroscopic couple set up, and 2. The reaction between the wheel and rail due to this couple.
8. A four-wheeled trolley car of total mass 2000 kg running on rails of 1.6 m gauge, rounds a curve of 30 m radius at 54 km/h. The track is banked at 8°. The wheels have an external diameter of 0.7 m and each pair with axle has a mass of 200 kg. The radius of gyration for each pair is 0.3 m. The height of centre of gravity of the car above the wheel base is 1 m. Determine, allowing for centrifugal force and gyroscopic couple actions, the pressure on each rail.
9. A horizontal axle AB, 1 m long, is pivoted at the midpoint C. It carries a weight of 20 N at A and a wheel weighing 50 N at B. The wheel is made to spin at a speed of 600 r.p.m in a clockwise direction looking from its front. Assuming that the weight of the flywheel is uniformly distributed around the rim whose mean diameter is 0.6 m; calculate the angular velocity of precession of the system around the vertical axis through C.



## ASSIGNMENT QUESTIONS

1. Explain the effect of the gyroscopic couple on the reaction of the four wheels of a vehicle negotiating a curve
2. Discuss the effect of the gyroscopic couple on a two wheeled vehicle when taking a turn.
3. What will be the effect of the gyroscopic couple on a disc fixed at a certain angle to a rotating shaft?
4. A uniform disc of 150 mm diameter has a mass of 5 kg. It is mounted centrally in bearings which maintain its axle in a horizontal plane. The disc spins about its axle with a constant speed of 1000 r.p.m. while the axle precesses uniformly about the vertical at 60 r.p.m. The directions of rotation are as shown in Fig. 14.3. If the distance between the bearings is 100 mm, find the resultant reaction at each bearing due to the mass and gyroscopic effects.
5. An aeroplane makes a complete half circle of 50 metres radius, towards left, when flying at 200 km per hr. The rotary engine and the propeller of the plane has a mass of 400 kg and a radius of gyration of 0.3 m. The engine rotates at 2400 r.p.m. clockwise when viewed from the rear. Find the gyroscopic couple on the aircraft and state its effect on it.
6. The turbine rotor of a ship has a mass of 8 tonnes and a radius of gyration 0.6 m. It rotates at 1800 r.p.m. clockwise, when looking from the stern. Determine the gyroscopic couple, if the ship travels at 100 km/hr and steers to the left in a curve of 75 m radius.
7. The heavy turbine rotor of a sea vessel rotates at 1500 r.p.m. clockwise looking from the stern, its mass being 750 kg. The vessel pitches with an angular velocity of 1 rad/s. Determine the gyroscopic couple transmitted to the hull when bow is rising, if the radius of gyration for the rotor is 250 mm. Also show in what direction the couple acts on the hull?
8. The turbine rotor of a ship has a mass of 3500 kg. It has a radius of gyration of 0.45 m and a speed of 3000 r.p.m. clockwise when looking from stern. Determine the gyroscopic couple and its effect upon the ship:
  1. when the ship is steering to the left on a curve of 100 m radius at a speed of 36 km/h.
  2. when the ship is pitching in a simple harmonic motion, the bow falling with its maximum velocity. The period of pitching is 40 seconds and the total angular displacement between the two extreme positions of pitching is 12 degrees.
9. A ship propelled by a turbine rotor which has a mass of 5 tonnes and a speed of 2100 r.p.m. The rotor has a radius of gyration of 0.5 m and rotates in a clockwise direction when viewed from the stern. Find the gyroscopic effects in the following conditions:



1. The ship sails at a speed of 30 km/h and steers to the left in a curve having 60 m radius.
2. The ship pitches 6 degree above and 6 degree below the horizontal position. The bow is descending with its maximum velocity. The motion due to pitching is simple harmonic and the periodic time is 20 seconds.
3. The ship rolls and at a certain instant it has an angular velocity of 0.03 rad/s clockwise when viewed from stern.

Determine also the maximum angular acceleration during pitching. Explain how the direction of motion due to gyroscopic effect is determined in each case.





---

# UNIT 3

# GOVERNORS

---



## **Course Objectives**

To understand the working principles of different type governors and its characteristics

## **Course Outcomes**

Student gets the exposure of different governors and its working principle





## INTRODUCTION

The function of a governor is to regulate the mean speed of an engine, when there are variations in the load *e.g.* when the load on an engine increases, its speed decreases, Therefore it becomes necessary to increase the supply of working fluid. On the other hand, when the load on the engine decreases, its speed increases and thus less working fluid is required. The governor automatically controls the supply of working fluid to the engine with the varying load conditions and keeps the mean speed within certain limits. A little consideration will show, that when the load increases, the configuration of the governor changes and a valve is moved to increase the supply of the working fluid **conversely**, when the load decreases, the engine speed increases and the governor decreases the supply of working fluid.

Classifications of the governor

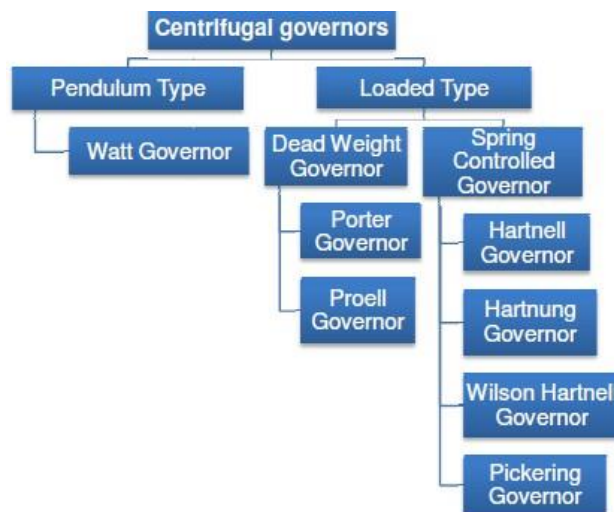

### Centrifugal Governors

The centrifugal governors are based on the balancing of centrifugal force on the rotating balls by an equal and opposite radial force, known as the controlling force\*. It consists of two balls of equal mass, which are attached to the arms as shown in Fig. These balls are known as governor balls or fly balls. The balls revolve with a spindle, which is driven by the engine through bevel gears. The upper ends of the arms are pivoted to the spindle, so that the balls may rise up or fall down as they revolve about the vertical axis. The arms are connected by the links to a sleeve, which is keyed to the spindle. This sleeve revolves with the spindle but can slide up and down. The balls and the sleeve rise when the spindle speed increases, and falls when the speed decreases. In order to limit the travel of the sleeve in upward and downward directions, two stops *S, S* are provided on the spindle. The sleeve is connected by a bell crank lever to a throttle valve. The supply of the working fluid decreases when the sleeve rises and increases when it falls. When the load on the engine increases, the engine



and the governor speed decreases. This results in the decrease of centrifugal force on the balls. Hence the balls move inwards and the sleeve moves downwards. The downward movement of the sleeve operates a throttle valve at the other end of the bell crank lever to

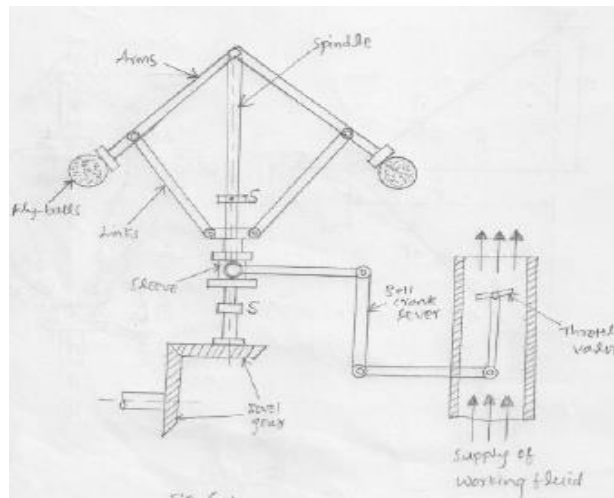

increase the supply of working fluid and thus the engine speed is increased.

In this case, the extra power output is provided to balance the increased load. When the load on the engine decreases, the engine and the governor speed increases, which results in the increase of centrifugal force on the balls. Thus the balls move outwards and the sleeve rises upwards. This upward movement of the sleeve reduces the supply of the working fluid and hence the speed is decreased. In this case, the power output is reduced.

### Watt Governor

The simplest form of a centrifugal governor is a Watt governor, as shown in Fig. It is basically a conical pendulum with links attached to a sleeve of negligible mass. The arms of the governor may be connected to the spindle in the following three ways governor may be connected to the spindle in the following three ways:

The pivot  $P$ , may be on the spindle axis as shown in Fig.(a).

The pivot  $P$ , may be offset from the spindle axis and the arms when produced intersect at  $O$ , as shown in Fig.(b).

The pivot  $P$ , may be offset, but the arms cross the axis at  $O$ , as shown in Fig(a)

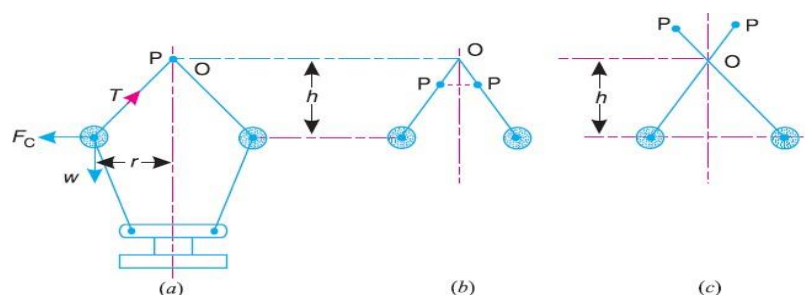

Let  $m$  = Mass of the ball in kg,

$w$  = Weight of the ball in newtons =  $m.g$ ,  $T$  = Tension in the arm in newtons,

$\omega$  = Angular velocity of the arm and ball about the spindle axis in rad/s,

$r$  = Radius of the path of rotation of the ball i.e. horizontal distance from the centre of the ball to the spindle axis in metres,

$F_c$  = Centrifugal force acting on the ball in newtons =  $m.\omega^2.r$ , and

$h$  = Height of the governor in metres.

It is assumed that the weight of the arms, links and the sleeve are negligible as compared to the weight of the balls. Now, the ball is in equilibrium under the action of the centrifugal force ( $F_c$ ) acting on the ball, the tension ( $T$ ) in the arm, and the weight ( $w$ ) of the ball.

Taking moments about point  $O$ , we have

$$F_c \times h = w \times r = m.g.r$$

$$m.\omega^2.r.h = m.g.r \quad \text{or} \quad h = g/\omega^2$$

When  $g$  is expressed in  $m/s^2$  and  $\omega$  in rad/s, then  $h$  is in metres. If  $N$  is the speed in r.p.m., then

$$\omega = 2\pi N/60$$

$$h = \frac{9.81}{(2\pi N/60)^2} = \frac{895}{N^2} \text{ metres}$$

### Porter Governor

The Porter governor is a modification of a Watt's governor, with central load attached to the sleeve as shown in Fig (a). The load moves up and down the central spindle. This additional downward force increases the speed of revolution required to enable the balls to rise to any predetermined level. Consider the forces acting on one-half of the governor as shown in Fig (b)

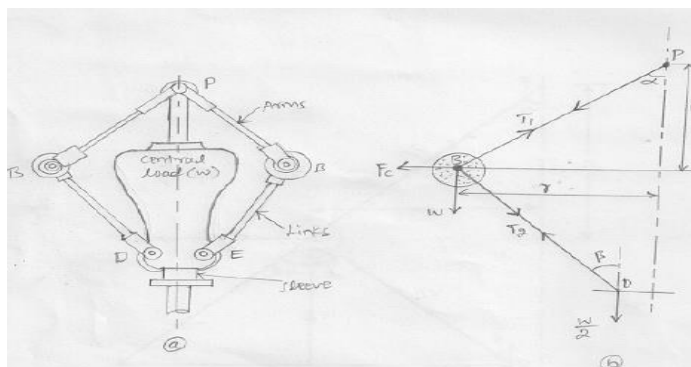

Let  $m$  = Mass of each ball in kg,

$w$  = Weight of each ball in newtons =  $m.g$ ,  $M$  = Mass of the central load in kg,

$W$  = Weight of the central load in newtons =  $M.g$ ,  $r$  = Radius of rotation in metres,



$h$  = Height of governor in metres ,

$N$  = Speed of the balls in r.p.m .,

$\omega$  = Angular speed of the balls in rad/s

=  $2\pi N/60$  rad/s,

$F_C$  = Centrifugal force acting on the ball in newtons =  $m.\omega^2.r$ ,

$T_1$  = Force in the arm in newtons,

$T_2$  = Force in the link in newtons,

$\alpha$  = Angle of inclination of the arm (or upper link) to the vertical, and

$\beta$  = Angle of inclination of the link (or lower link) to the vertical.

Though there are several ways of determining the relation between the height of the governor ( $h$ ) and the angular speed of the balls ( $\omega$ ), yet the following two methods are important from the subject point of view.

### Method of resolution of forces Instantaneous centre method

#### Method of resolution of forces

Considering the equilibrium of the forces acting at  $D$ , we have

$$T_2 \cos \beta = \frac{W}{2} = \frac{M \cdot g}{2}$$
$$T_2 = \frac{M \cdot g}{2 \cos \beta}$$

Again, considering the equilibrium of the forces acting on  $B$ . The point  $B$  is in equilibrium under the action of the following forces, as shown in Fig(b).

The weight of ball ( $w = m.g$ ),

The centrifugal force ( $F_C$ ),

The tension in the arm ( $T_1$ ), and

The tension in the link ( $T_2$ ).

Resolving the forces vertically,

$$T_1 \cos \alpha = T_2 \cos \beta + w = \frac{M \cdot g}{2} + m.g \quad \dots (ii)$$

Resolving the forces horizontally,

$$T_1 \sin \alpha + T_2 \sin \beta = F_C$$

$$T_1 \sin \alpha + \frac{M \cdot g}{2 \cos \beta} \times \sin \beta = F_C \quad \dots \left( \because T_2 = \frac{M \cdot g}{2 \cos \beta} \right)$$

$$T_1 \sin \alpha + \frac{M \cdot g}{2} \times \tan \beta = F_C$$

$$T_1 \sin \alpha = F_C - \frac{M \cdot g}{2} \times \tan \beta \quad \dots (iii)$$

Dividing equation (iii) by equation (ii),

$$\frac{T_1 \sin \alpha}{T_1 \cos \alpha} = \frac{F_C - \frac{M \cdot g}{2} \times \tan \beta}{\frac{M \cdot g}{2} + m.g}$$



or 
$$\left( \frac{M \cdot g}{2} + m \cdot g \right) \tan \alpha = F_C - \frac{M \cdot g}{2} \times \tan \beta$$

$$\frac{M \cdot g}{2} + m \cdot g = \frac{F_C}{\tan \alpha} - \frac{M \cdot g}{2} \times \frac{\tan \beta}{\tan \alpha}$$

Substituting  $\frac{\tan \beta}{\tan \alpha} = q$ , and  $\tan \alpha = \frac{r}{h}$ , we have

Instantaneous centre method

$$\frac{M \cdot g}{2} + m \cdot g = m \cdot \omega^2 \cdot r \times \frac{h}{r} - \frac{M \cdot g}{2} \times q \quad \dots (\because F_C = m \cdot \omega^2 \cdot r)$$

$$m \cdot \omega^2 \cdot h = m \cdot g + \frac{M \cdot g}{2} (1 + q)$$

$$\omega^2 = \left[ m \cdot g + \frac{M \cdot g}{2} (1 + q) \right] \frac{1}{m \cdot h} = \frac{m + \frac{M}{2} (1 + q)}{m} \times \frac{g}{h}$$

$$\left( \frac{2\pi N}{60} \right)^2 = \frac{m + \frac{M}{2} (1 + q)}{m} \times \frac{g}{h}$$

$$N^2 = \frac{m + \frac{M}{2} (1 + q)}{m} \times \frac{g}{h} \left( \frac{60}{2\pi} \right)^2 = \frac{m + \frac{M}{2} (1 + q)}{m} \times \frac{895}{h} \quad \dots (v)$$

In this method, equilibrium of the forces acting on the link  $BD$  are considered. The instantaneous centre/ lies at the point of intersection of  $PB$  produced and a line through  $D$  perpendicular to the spindle axis, as shown in Fig. 18.4. Taking moments about the point/

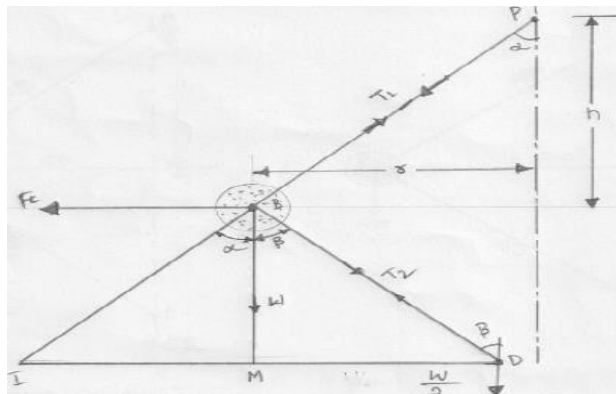

$$F_C \times BM = w \times IM + \frac{W}{2} \times ID$$

$$= m \cdot g \times IM + \frac{M \cdot g}{2} \times ID$$

$$F_C = m \cdot g \times \frac{IM}{BM} + \frac{M \cdot g}{2} \times \frac{ID}{BM}$$

$$= m \cdot g \times \frac{IM}{BM} + \frac{M \cdot g}{2} \left( \frac{IM + MD}{BM} \right)$$

$$= m \cdot g \times \frac{IM}{BM} + \frac{M \cdot g}{2} \left( \frac{IM}{BM} + \frac{MD}{BM} \right)$$

$$= m \cdot g \tan \alpha + \frac{M \cdot g}{2} (\tan \alpha + \tan \beta)$$

$$\therefore m \omega^2 \cdot r \times \frac{h}{r} = m \cdot g + \frac{M \cdot g}{2} (1+q)$$

$$h = \frac{m \cdot g + \frac{M \cdot g}{2} (1+q)}{m} \times \frac{1}{\omega^2} = \frac{m + \frac{M}{2} (1+q)}{m} \times \frac{g}{\omega^2}$$

... (Same as before)

When  $\tan \alpha = \tan \beta$  or  $q = 1$ , then

$$h = \frac{m + M}{m} \times \frac{g}{\omega^2}$$

## PROBLEMS

**Example1.** A Porter governor has equal arms each 250 mm long and pivoted on the axis of rotation. Each ball has a mass of 5 kg and the mass of the central load on the sleeve is 25 kg. The radius of rotation of the ball is 150 mm when the governor begins to lift and 200 mm when the governor is at maximum speed. Find the minimum and maximum speeds and range of speed of the governor.

**Solution.** Given :  $BP = BD = 250 \text{ mm} = 0.25 \text{ m}$  ;  $m = 5 \text{ kg}$  ;  $M = 15 \text{ kg}$  ;

$r_1 = 150 \text{ mm} = 0.15 \text{ m}$  ;  $r_2 = 200 \text{ mm} = 0.2 \text{ m}$

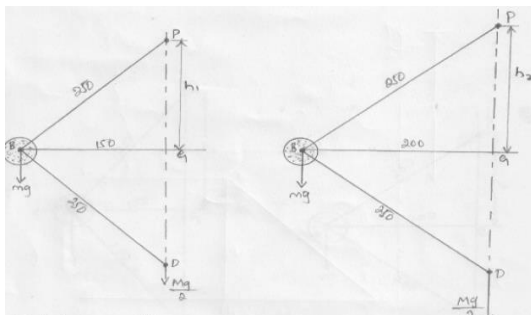

The minimum and maximum positions of the governor are shown in Fig.(a) and (b) respectively.



Minimum speed when  $r_1 = BG = 0.15 \text{ m}$

Let  $N_1 = \text{Minimum speed.}$

From Fig.(a), we find that height of the governor,

$$h_1 = PG = \sqrt{(PB)^2 - (BG)^2} = \sqrt{(0.25)^2 - (0.15)^2} = 0.2 \text{ m}$$

We know that

$$(N_1)^2 = \frac{m + M}{m} \times \frac{895}{h_1} = \frac{5 + 15}{5} \times \frac{895}{0.2} = 17\,900$$

$N_1 = 133.8 \text{ r.p.m.}$

Maximum speed when  $r_2 = BG = 0.2 \text{ m}$  Let  $N_2 = \text{Maximum speed.}$

From Fig(b), we find that height of the governor,

$$h_2 = PG = \sqrt{(PB)^2 - (BG)^2} = \sqrt{(0.25)^2 - (0.2)^2} = 0.15 \text{ m}$$

$$(N_2)^2 = \frac{m + M}{m} \times \frac{895}{h_2} = \frac{5 + 15}{5} \times \frac{895}{0.15} = 23\,867$$

$N_2 = 154.5 \text{ r.p.m.}$

Range of speed

We know that range of speed =  $N_2 - N_1 = 154.4 - 133.8 = 20.7 \text{ r.p.m.}$

## Proell Governor

The Proell governor has the balls fixed at  $B$  and  $C$  to the extension of the links  $DF$  and  $EG$ , as shown in Fig(a). The arms  $FP$  and  $GQ$  are pivoted at  $P$  and  $Q$  respectively.

Consider the equilibrium of the forces on one-half of the governor as shown in Fig (b).The instantaneous centre ( $I$ ) lies on the intersection of the line  $PF$  produced and the line from  $D$  drawn perpendicular to the spindle axis. The perpendicular  $BM$  is drawn on  $ID$ .

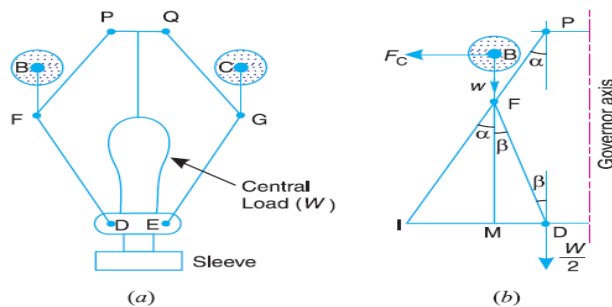

Taking moments about  $I$ ,

$$F_C \times BM = w \times IM + \frac{W}{2} \times ID = m \cdot g \times IM + \frac{M \cdot g}{2} \times ID \quad \dots (i)$$

$$\therefore F_C = m \cdot g \times \frac{IM}{BM} + \frac{M \cdot g}{2} \left( \frac{IM + MD}{BM} \right) \quad \dots (\because ID = IM + MD)$$

Multiplying and dividing by  $FM$ , we have



$$\begin{aligned}
 F_C &= \frac{FM}{BM} \left[ m \cdot g \times \frac{IM}{FM} + \frac{M \cdot g}{2} \left( \frac{IM}{FM} + \frac{MD}{FM} \right) \right] \\
 &= \frac{FM}{BM} \left[ m \cdot g \times \tan \alpha + \frac{M \cdot g}{2} (\tan \alpha + \tan \beta) \right] \\
 &= \frac{FM}{BM} \times \tan \alpha \left[ m \cdot g + \frac{M \cdot g}{2} \left( 1 + \frac{\tan \beta}{\tan \alpha} \right) \right]
 \end{aligned}$$

We know that  $F_C = m \cdot \omega^2 r$ ;  $\tan \alpha = \frac{r}{h}$  and  $q = \frac{\tan \beta}{\tan \alpha}$

$$\therefore m \cdot \omega^2 \cdot r = \frac{FM}{BM} \times \frac{r}{h} \left[ m \cdot g + \frac{M \cdot g}{2} (1 + q) \right]$$

and 
$$\omega^2 = \frac{FM}{BM} \left[ \frac{m + \frac{M}{2} (1 + q)}{m} \right] \frac{g}{h} \quad \dots (ii)$$

Substituting  $\omega = 2\pi N/60$ , and  $g = 9.81 \text{ m/s}^2$ , we get

$$N^2 = \frac{FM}{BM} \left[ \frac{m + \frac{M}{2} (1 + q)}{m} \right] \frac{895}{h} \quad \dots (iii)$$

## PROBLEMS

**Example 1.** A Proell governor has equal arms of length 300 mm. The upper and lower ends of the arms are pivoted on the axis of the governor. The extension arms of the lower links are each 80 mm long and parallel to the axis when the radii of rotation of the balls are 150 mm and 200 mm. The mass of each ball is 10 kg and the mass of the central load is 100 kg. Determine the range of speed of the governor.

**Solution.** Given :  $PF = DF = 300 \text{ mm}$  ;  $BF = 80 \text{ mm}$  ;  $m = 10 \text{ kg}$  ;  $M = 100 \text{ kg}$  ;

$r_1 = 150 \text{ mm}$ ;  $r_2 = 200 \text{ mm}$

First of all, let us find the minimum and maximum speed of the governor. The minimum and maximum position of the governor is shown in Fig (a) Let

$N_1 =$  Minimum speed when radius of rotation,  $r_1 = FG = 150 \text{ mm}$ ;

$N_2 =$  Maximum speed when radius of rotation,  $r_2 = FG = 200 \text{ mm}$ .

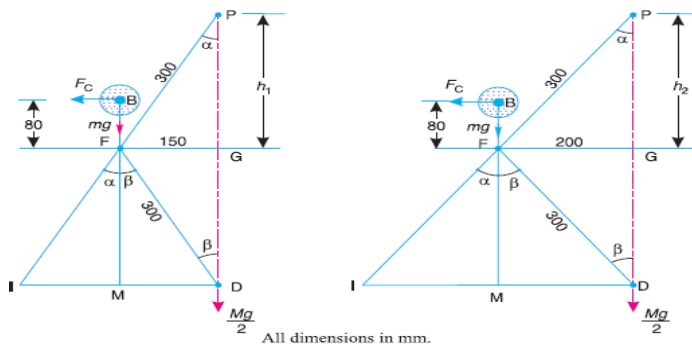

(a) Minimum position.

(a) Maximum position.

From Fig(a), we find that height of the governor,





$$FM = GD = PG = 260 \text{ mm} = 0.26 \text{ m}$$

$$BM = BF + FM = 80 + 260 = 340 \text{ mm} = 0.34 \text{ m}$$

We know that  $(N_1)^2 = \frac{FM}{BM} \left( \frac{m+M}{m} \right) \frac{895}{h_1} \dots (\because \alpha = \beta \text{ or } q = 1)$

$$= \frac{0.26}{0.34} \left( \frac{10+100}{10} \right) \frac{895}{0.26} = 28\,956 \text{ or } N_1 = 170 \text{ r.p.m.}$$

Now from Fig. 18.13 (b), we find that height of the governor,

$$h_2 = PG = \sqrt{(PF)^2 - (FG)^2} = \sqrt{(300)^2 - (200)^2} = 224 \text{ mm} = 0.224 \text{ m}$$

$$FM = GD = PG = 224 \text{ mm} = 0.224 \text{ m}$$

$$\therefore BM = BF + FM = 80 + 224 = 304 \text{ mm} = 0.304 \text{ m}$$

We know that  $(N_2)^2 = \frac{FM}{BM} \left( \frac{m+M}{m} \right) \frac{895}{h_2} \dots (\because \alpha = \beta \text{ or } q = 1)$

$$= \frac{0.224}{0.304} \left( \frac{10+100}{10} \right) \frac{895}{0.224} = 32\,385 \text{ or } N_2 = 180 \text{ r.p.m.}$$

We know that range of speed

$$= N_2 - N_1 = 180 - 170 = 10 \text{ r.p.m. Ans.}$$

## Hartnell Governor

A Hartnell governor is a spring loaded governor as shown in Fig. It consists of two bell crank levers pivoted at the points  $O, O$  to the frame. The frame is attached to the governor spindle and therefore rotates with it. Each lever carries a ball at the end of the vertical arm  $OB$  and a roller at the end of the horizontal arm  $OR$ . A helical spring in compression provides equal downward forces on the two rollers through a collar on the sleeve. The spring force may be adjusted by screwing a nut up or down on the sleeve.

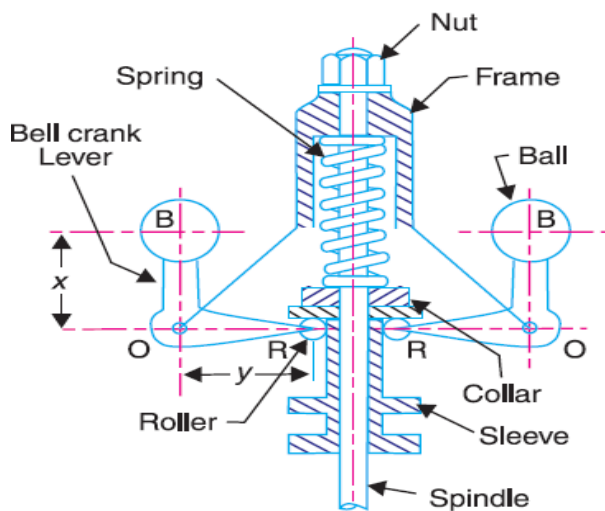

$m$  = Mass of each ball in kg,

$M$  = Mass of sleeve in kg,

$r_1$  = Minimum radius of rotation in metres,

$r_2$  = Maximum radius of rotation in metres,



$\omega_1$  = Angular speed of the governor at minimum radius in rad/s,  $\omega_2$  = Angular speed of the governor at maximum radius in rad/s,  $S_1$  = Spring force exerted on the sleeve at  $\omega_1$  in newtons,

$S_2$  = Spring force exerted on the sleeve at  $\omega_2$  in newtons,  $F_{C1}$  = Centrifugal force at  $\omega_1$  in newtons =  $m (\omega_1)^2 r_1$ ,  $F_{C2}$  = Centrifugal force at  $\omega_2$  in newtons =  $m (\omega_2)^2 r_2$ ,

$s$  = Stiffness of the spring or the force required to compress the spring by one mm,

$x$  = Length of the vertical or ball arm of the lever in metres,

$y$  = Length of the horizontal or sleeve arm of the lever in metres, and

$r$  = Distance of fulcrum  $O$  from the governor axis or the radius of rotation when the governor is in mid-position, in metres.

Consider the forces acting at one bell crank lever. The minimum and maximum position is shown in Fig. Let  $h$  be the compression of the spring when the radius of rotation changes from  $r_1$  to  $r_2$ .

For the minimum position *i.e.* when the radius of rotation changes from  $r$  to  $r_1$ , as shown in

$$\frac{h_1}{y} = \frac{a_1}{x} = \frac{r - r_1}{x}$$

Fig (a), the compression of the spring or the lift of sleeve  $h_1$  is given by

Similarly, for the maximum position *i.e.* when the radius of rotation changes from  $r$  to  $r_2$ , as shown in Fig (b), the compression of the spring or lift of sleeve  $h_2$  is given by

$$\frac{h_2}{y} = \frac{a_2}{x} = \frac{r_2 - r}{x}$$

Adding equations (i) and (ii),

$$\frac{h_1 + h_2}{y} = \frac{r_2 - r_1}{x} \quad \text{or} \quad \frac{h}{y} = \frac{r_2 - r_1}{x} \quad \dots (\because h = h_1 + h_2)$$

$$\therefore h = (r_2 - r_1) \frac{y}{x} \quad \dots (iii)$$

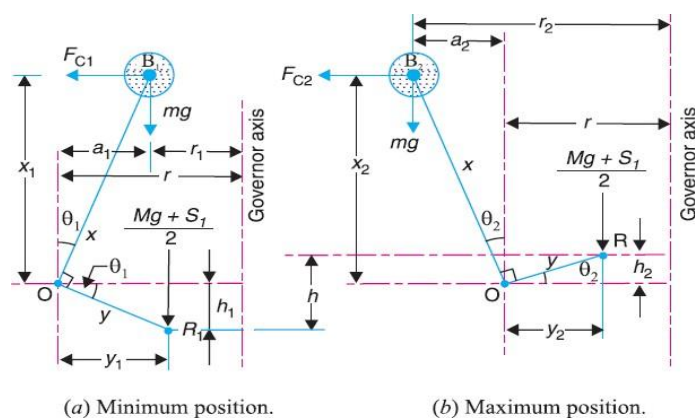

Now for minimum position, taking moments about point  $O$ , we get



$$S_2 - S_1 = h.s, \quad \text{and} \quad h = (r_2 - r_1) \frac{y}{x}$$

$$s = \frac{S_2 - S_1}{h} = 2 \left( \frac{F_{C2} - F_{C1}}{r_2 - r_1} \right) \left( \frac{x}{y} \right)^2 \quad \dots (ix) \quad \dots (iv)$$

Again for maximum position, taking moments about point  $O$ , we get

$$\frac{M.g + S_2}{2} \times y_2 = F_{C2} \times x_2 + m.g \times a_2$$

$$M.g + S_2 = \frac{2}{y_2} (F_{C2} \times x_2 + m.g \times a_2) \quad \dots (v)$$

Subtracting equation (iv) from equation (v),

$$S_2 - S_1 = \frac{2}{y_2} (F_{C2} \times x_2 + m.g \times a_2) - \frac{2}{y_1} (F_{C1} \times x_1 - m.g \times a_1)$$

We know that

$$S_2 - S_1 = h.s, \quad \text{and} \quad h = (r_2 - r_1) \frac{y}{x}$$

$$\therefore s = \frac{S_2 - S_1}{h} = \left( \frac{S_2 - S_1}{r_2 - r_1} \right) \frac{x}{y}$$

Neglecting the obliquity effect of the arms (*i.e.*  $x_1 = x_2 = x$ , and  $y_1 = y_2 = y$ ) and the moment due to weight of the balls (*i.e.*  $m.g$ ), we have for minimum position,

$$\frac{M.g + S_1}{2} \times y = F_{C1} \times x \quad \text{or} \quad M.g + S_1 = 2F_{C1} \times \frac{x}{y} \quad \dots (vi)$$

Similarly for maximum position,

$$\frac{M.g + S_2}{2} \times y = F_{C2} \times x \quad \text{or} \quad M.g + S_2 = 2F_{C2} \times \frac{x}{y} \quad \dots (vii)$$

Subtracting equation (vi) from equation (vii),

$$S_2 - S_1 = 2 (F_{C2} - F_{C1}) \frac{x}{y} \quad \dots (viii)$$

## PROBLEMS

Example1. A Hartnell governor having a central sleeve spring and two right-angled bell crank levers moves between 290 r.p.m. and 310 r.p.m. for a sleeve lift of 15 mm. The sleeve arm sand the ball arms are 80 mm and 120 mm respectively. The levers are pivoted at 120 mm from the governor axis and mass of each ball is 2.5 kg. The ball arms are parallel to the



governor axis at the lowest equilibrium speed. Determine loads on the spring at the lowest and the highest equilibrium speeds, and Stiffness of the spring.

**Solution.** Given :  $N_1 = 290$  r.p.m. or  $\omega_1 = 2\pi \times 290/60 = 30.4$  rad/s ;  $N_2 = 310$  r.p.m. or  $\omega_2 = 2\pi \times 310/60 = 32.5$  rad/s ;  $h = 15$  mm = 0.015 m ;  $y = 80$  mm = 0.08 m ;  $x = 120$  mm = 0.12 m ;  $r = 120$  mm = 0.12 m ;  $m = 2.5$  kg  
Loads on the spring at the lowest and highest equilibrium speeds

Let  $S_1$  = Spring load at lowest equilibrium speed, and

$S_2$  = Spring load at highest equilibrium speed.

Since the ball arms are parallel to governor axis at the lowest equilibrium speed (*i.e.* at  $N_1 = 290$  r.p.m.), as shown in Fig(a), therefore

$$r = r_1 = 120 \text{ mm} = 0.12 \text{ m}$$

We know that centrifugal force at the minimum speed,

$$F_{C1} = m (\omega_1)^2 r_1 = 2.5 (30.4)^2 0.12 = 277 \text{ N}$$

Now let us find the radius of rotation at the highest equilibrium speed, *i.e.* at

$N_2 = 310$  r.p.m. The position of ball arm and sleeve arm at the highest equilibrium speed is shown in Fig(b).

Let  $r_2$  = Radius of rotation at  $N_2 = 310$  r.p.m.

We know that 
$$h = (r_2 - r_1) \frac{y}{x}$$

$$r_2 = r_1 + h \left( \frac{x}{y} \right) = 0.12 + 0.015 \left( \frac{0.12}{0.08} \right) = 0.1425 \text{ m}$$

Centrifugal force at the maximum speed,

$$F_{C2} = m (\omega_2)^2 r_2 = 2.5 \times (32.5)^2 \times 0.1425 = 376 \text{ N}$$

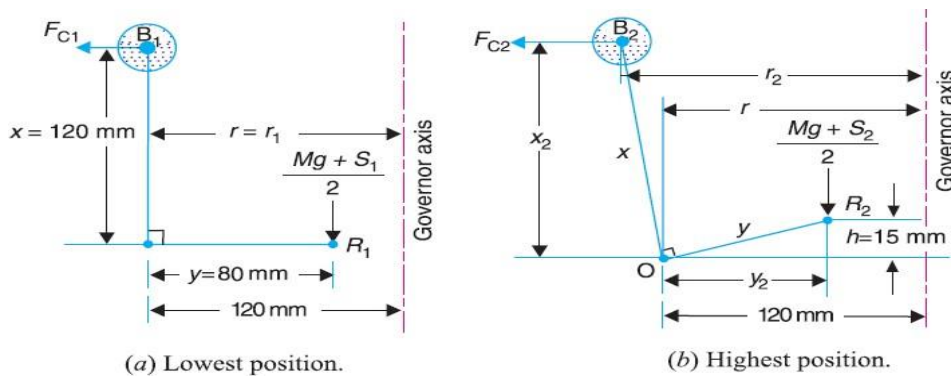

Neglecting the obliquity effect of arms and the moment due to the weight of the balls, we have for lowest position,



$$M \cdot g + S_1 = 2F_{C1} \times \frac{x}{y} = 2 \times 277 \times \frac{0.12}{0.08} = 831 \text{ N}$$

$$S_2 = 831 \text{ N Ans.} \quad (\because M = 0)$$

and for highest position,

$$M \cdot g + S_2 = 2F_{C2} \times \frac{x}{y} = 2 \times 376 \times \frac{0.12}{0.08} = 1128 \text{ N}$$

$$\therefore S_1 = 1128 \text{ N Ans.} \quad (\because M = 0)$$

Stiffness of the spring

We know that stiffness of the spring,

$$s = \frac{S_2 - S_1}{h} = \frac{1128 - 831}{15} = 19.8 \text{ N/mm}$$

### Hartung Governor

A spring controlled governor of the Hartung type is shown in Fig. (a). In this type of governor, the vertical arms of the bell crank levers are fitted with spring balls which compress against the frame of the governor when the rollers at the horizontal arm press against the sleeve.

Let  $S$  = Spring force,

$F_C$  = Centrifugal force,

$M$  = Mass on the sleeve, and

$x$  and  $y$  = Lengths of the vertical and horizontal arm of the bell crank lever respectively.

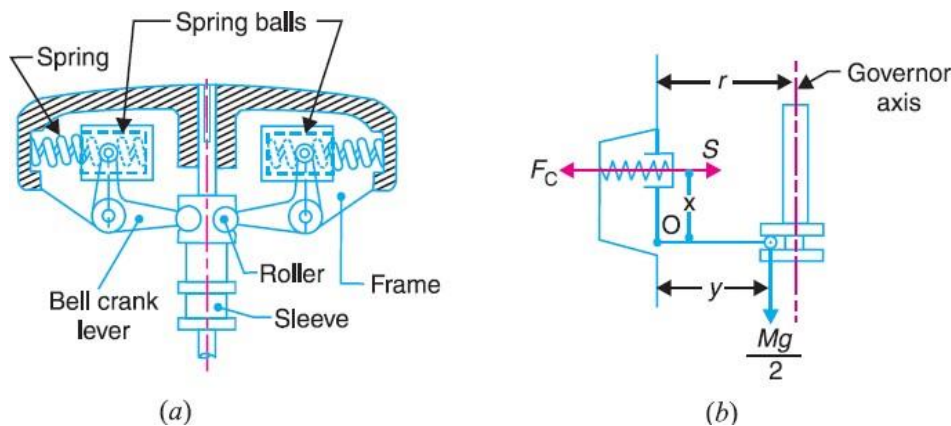

Fig (a) and (b) show the governor in mid-position. Neglecting the effect of obliquity of the arms, taking moments about the fulcrum O,

$$F_C \times x = S \times x + \frac{M \cdot g}{2} \times y$$



## Sensitiveness of Governors

Consider two governors  $A$  and  $B$  running at the same speed. When this speed increases or decreases by a certain amount, the lift of the sleeve of governor  $A$  is greater than the lift of the sleeve of governor  $B$ . It is then said that the governor  $A$  is more sensitive than the governor  $B$ .

In general, the greater the lift of the sleeve corresponding to a given fractional change in speed, the greater is the sensitiveness of the governor. It may also be stated in another way that for a given lift of the sleeve, the sensitiveness of the governor increases as the speed range decreases. This definition of sensitiveness may be quite satisfactory when the governor is considered as an independent mechanism. But when the governor is fitted to an engine, the practical requirement is simply that the change of equilibrium speed from the full load to the no load position of the sleeve should be as small a fraction as possible of the mean equilibrium speed.

The actual displacement of the sleeve is immaterial, provided that it is sufficient to change the energy supplied to the engine by the required amount. For this reason, the sensitiveness is defined as the **ratio of the difference between the maximum and minimum equilibrium speeds to the mean equilibrium speed**

Let  $N_1$  = Minimum equilibrium speed,

$N_2$  = Maximum equilibrium speed, and

$N$  = Mean equilibrium speed =  $(N_1 + N_2)/2$

∴ Sensitiveness of the governor

$$\begin{aligned} &= \frac{N_2 - N_1}{N} = \frac{2(N_2 - N_1)}{N_1 + N_2} \\ &= \frac{2(\omega_2 - \omega_1)}{\omega_1 + \omega_2} \quad \dots \text{(In terms of angular speeds)} \end{aligned}$$

## Stability of Governors

A governor is said to be **stable** when for every speed within the working range there is a definite configuration *i.e.* there is only one radius of rotation of the governor balls at which the governor is in equilibrium. For a stable governor, if the equilibrium speed increases, the radius of governor balls must also increase.

## Isochronous Governors

A governor is said to be **isochronous** when the equilibrium speed is constant (*i.e.* range of speed is zero) for all radii of rotation of the balls within the working range, neglecting friction. The isochronism is the stage of infinite sensitivity.

Let us consider the case of a Porter governor running at speeds  $N_1$  and  $N_2$  r.p.m.



$$(N_1)^2 = \frac{m + \frac{M}{2}(1+q)}{m} \times \frac{895}{h_1} \quad \dots (i)$$

$$(N_2)^2 = \frac{m + \frac{M}{2}(1+q)}{m} \times \frac{895}{h_2} \quad \dots (ii)$$

For isochronisms, range of speed should be zero i.e.  $N_2 - N_1 = 0$  or  $N_2 = N_1$ . Therefore from equations (i) and (ii),  $h_1 = h_2$ , which is impossible in case of a Porter governor. Hence a **Porter governor cannot be isochronous**.

Now consider the case of a Hartnell governor running at speeds  $N_1$  and  $N_2$  r.p.m.

$$M \cdot g + S_1 = 2 F_{C1} \times \frac{x}{y} = 2 \times m \left( \frac{2\pi N_1}{60} \right)^2 r_1 \times \frac{x}{y} \quad \dots (iii)$$

$$M \cdot g + S_2 = 2 F_{C2} \times \frac{x}{y} = 2 \times m \left( \frac{2\pi N_2}{60} \right)^2 r_2 \times \frac{x}{y} \quad \dots (iv)$$

$$\frac{M \cdot g + S_1}{M \cdot g + S_2} = \frac{r_1}{r_2}$$

For isochronisms,  $N_2 = N_1$ . Therefore from equations (iii) and (iv),  
Hunting

A governor is said to be **hunt** if the speed of the engine fluctuates continuously above and below the mean speed. This is caused by a too sensitive governor which changes the fuel supply by a large amount when a small change in the speed of rotation takes place. For example, when the load on the engine increases, the engine speed decreases and, if the governor is very sensitive, the governor sleeve immediately falls to its lowest position. This will result in the opening of the control valve wide which will supply the fuel to the engine in excess of its requirement so that the engine speed rapidly increases again and the governor sleeve rises to its highest position. Due to this movement of the sleeve, the control valve will cut off the fuel supply to the engine and thus the engine speed begins to fall once again. This cycle is repeated indefinitely. Such a governor may admit either the maximum or the minimum amount of fuel. The effect of this will be to cause wide fluctuations in the engine speed or in other words, the engine will hunt



## INDUSTRIAL APPLICATIONS

Diesel Generators



Gas Engine Governors

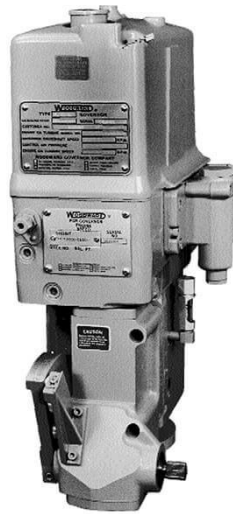

In steam Turbines





## TUTORIAL QUESTIONS

1. Explain types of governors?
2. A Porter governor has all four arms 250 mm long. The upper arms are attached on the axis of rotation and the lower arms are attached to the sleeve at a distance of 30 mm from the axis. The mass of each ball is 5 kg and the sleeve has a mass of 50 kg. The extreme radii of rotation are 150 mm and 200 mm. Determine the range of speed of the governor.
3. A Proell governor has equal arms of length 300 mm. The upper and lower ends of the arms are pivoted on the axis of the governor. The extension arms of the lower links are each 80 mm long and parallel to the axis when the radii of rotation of the balls are 150 mm and 200 mm. The mass of each ball is 10 kg and the mass of the central load is 100 kg. Determine the range of speed of the governor.
4. In a spring loaded Hartnell type governor, the extreme radii of rotation of the balls are 80 mm and 120 mm. The ball arm and the sleeve arm of the bell crank lever are equal in length. The mass of each ball is 2 kg. If the speeds at the two extreme positions are 400 and 420 r.p.m., find : 1. the initial compression of the central spring, and 2. the spring constant.
5. In a spring controlled governor of the type, as shown in Fig. 18.24, the mass of each ball is 1.5 kg and the mass of the sleeve is 8 kg. The two arms of the bell crank lever are at right angles and their lengths are  $OB = 100$  mm and  $OA = 40$  mm. The distance of the fulcrum O of each bell crank lever from the axis of rotation is 50 mm and minimum radius of rotation of the governor balls is also 50 mm. The corresponding equilibrium speed is 240 r.p.m. and the sleeve is required to lift 10 mm for an increase in speed of 5 per cent. Find the stiffness and initial compression of the spring
6. A spring loaded governor of the Wilson-Hartnell type is shown in Fig 18.50. Two balls each of mass 4 kg are connected across by two springs A. The stiffness of each spring is 750 N/m and a free length of 100 mm. The length of ball arm of each bell crank lever is 80 mm and that of sleeve arm is 60 mm. The lever is pivoted at its mid-point. The speed of the governor is 240 r.p.m. in its mean position and the radius of rotation of the ball is 80 mm. If the lift of the sleeve is 7.5 mm for an increase of speed of 5%, find the required stiffness of the auxiliary spring B.



## ASSIGNMENT QUESTIONS

1. The arms of a Porter governor are each 250 mm long and pivoted on the governor axis. The mass of each ball is 5 kg and the mass of the central sleeve is 30 kg. The radius of rotation of the balls is 150 mm when the sleeve begins to rise and reaches a value of 200 mm for maximum speed. Determine the speed range of the governor. If the friction at the sleeve is equivalent of 20 N of load at the sleeve, determine how the speed range is modified.
2. The arms of a Porter governor are 300 mm long. The upper arms are pivoted on the axis of rotation. The lower arms are attached to a sleeve at a distance of 40 mm from the axis of rotation. The mass of the load on the sleeve is 70 kg and the mass of each ball is 10 kg. Determine the equilibrium speed when the radius of rotation of the balls is 200 mm. If the friction is equivalent to a load of 20 N at the sleeve, what will be the range of speed for this position ?
3. A governor of the Proell type has each arm 250 mm long. The pivots of the upper and lower arms are 25 mm from the axis. The central load acting on the sleeve has a mass of 25 kg and the each rotating ball has a mass of 3.2 kg. When the governor sleeve is in mid-position, the extension link of the lower arm is vertical and the radius of the path of rotation of the masses is 175 mm. The vertical height of the governor is 200 mm. If the governor speed is 160 r.p.m. when in mid-position, find :  
1. length of the extension link; and 2. tension in the upper arm.
4. A Hartnell governor having a central sleeve spring and two right-angled bell crank levers moves between 290 r.p.m. and 310 r.p.m. for a sleeve lift of 15 mm. The sleeve arms and the ball arms are 80 mm and 120 mm respectively. The levers are pivoted at 120 mm from the governor axis and mass of each ball is 2.5 kg. The ball arms are parallel to the governor axis at the lowest equilibrium speed. Determine :  
1. loads on the spring at the lowest and the highest equilibrium speeds, and 2. stiffness of the spring.
5. In a spring-controlled governor of the Hartung type, the length of the ball and sleeve arms are 80 mm and 120 mm respectively. The total travel of the sleeve is 25 mm. In the mid position, each spring is compressed by 50 mm and the radius of rotation of the mass centres is 140 mm. Each ball has a mass of 4 kg and the spring has a stiffness of 10 kN/m of compression. The equivalent mass of the governor gear at the sleeve is 16 kg. Neglecting the moment due to the revolving masses when the arms are inclined, determine the ratio of the range of speed to the mean speed of the governor. Find, also, the speed in the mid-position.



6. Explain the term height of the governor. Derive an expression for the height in the case of a Watt governor. What are the limitations of a Watt governor ?
7. What is stability of a governor ?
8. Define and explain the following terms relating to governors : 1. Stability, 2. Sensitiveness, 3. Isochronism, and 4. Hunting

